

# SYNERGY SYSTEM™

Model: SNC20

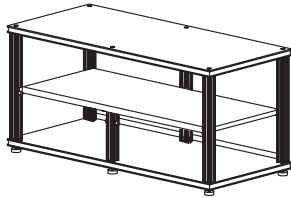

Model: SNC30

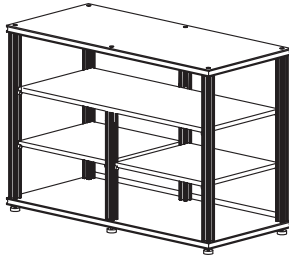

## BEFORE YOU BEGIN:

- Unpack all parts and read instructions carefully before beginning.
- Shelf pegs and door hinges must slide into the channels of the post in the correct order. They cannot be removed individually without disassembling the whole unit.

## 1 Connect Posts to Bottom Shelf

### A. Square Post

Square the post to the bottom shelf.

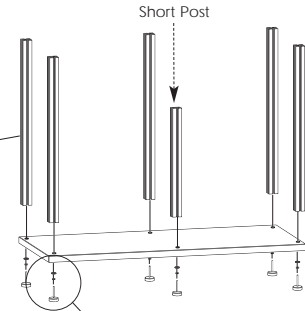
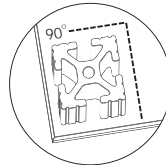

### B. Connect Post

Screw foot with metal washer through bottom shelf and into the end of each extruded post. Hand tighten fully and use wrench to tighten nut onto underside of shelf.

**WARNING:** Tighten by screwing the leveler foot NOT the post.

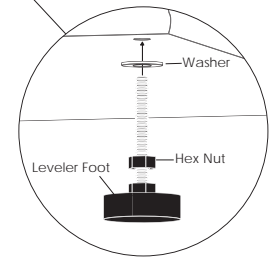

### Limited Warranty

Five full years Salamander Designs Ltd will repair or replace, at our option, any product defective in materials or craftsmanship. Salamander Designs Ltd. will not be responsible for any damage to or destruction of other equipment consequential to our equipment failure. Defective product must be given Return Authorization and is to be returned to the factory prepaid, in the original carton and packing material. Any damage incurred in a shipment not in original packaging shall be the responsibility of the owner. Warranty repairs will be returned prepaid, via UPS within the continental U.S.A. only.

## 2 Add Shelf Pegs

### A. Pegs for Shelves

Insert one shelf peg down each post.

**NOTE:** There are two varieties of shelf pegs (A and B). They are designed to cradle the shelf in place. Refer to drawing.

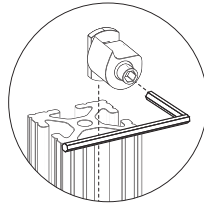
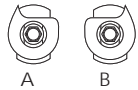

**Note:**

If installing door(s), use 2 sets of shelf pegs at the top of short posts to act as door stops.

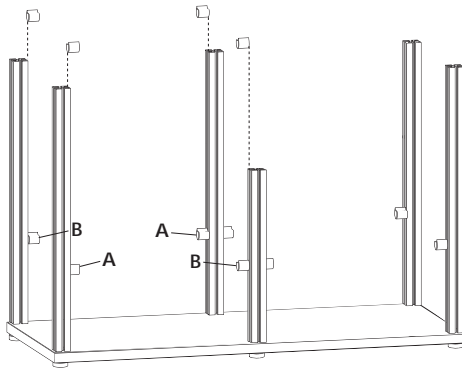

### B. Adjust Peg Height

Position the shelf peg through the Spacer Tool and tighten at desired height. See step 4 for fine tuning.

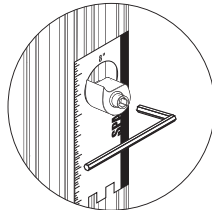

## 3 Attach Rear Panels

### A. Insert Hardware

Combine the 1" threaded studs with flat nuts. Slide 2 sets of hardware down the two outside posts and 4 sets down the center post. Allow studs to remain loose at bottom of post.

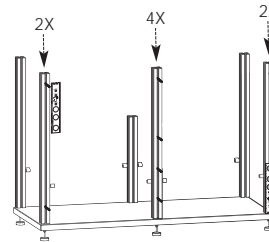
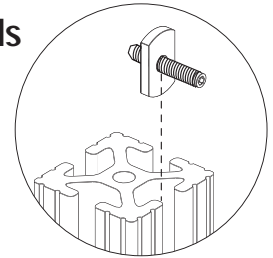

**TIP**

To ease installation of rear panels gently place the unit face down on the floor to improve aligning of panels.

### B. Position & Secure Studs

Align the Spacer Tool at the top of each post, then position top studs through the small "Rear Panel" hole. Repeat this step with the bottom studs aligning the Tool along the bottom of post to set spacing for cable passage. Use the hex key to secure the top and bottom studs to the posts.

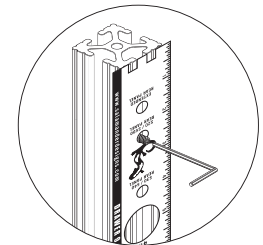

### C. Place Rear Panels

Secure each panel in place with thumb nuts.

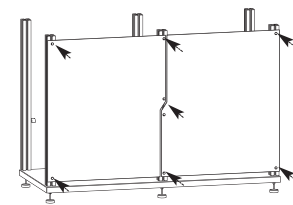
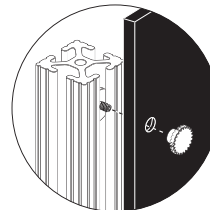

# 4

## Placing Shelves

If assembling model SNC20, skip to step C.

### A. Adjustable Shelves

Place shelves from the bottom up. Angle the shelf in between the front post and set on top of shelf pegs.

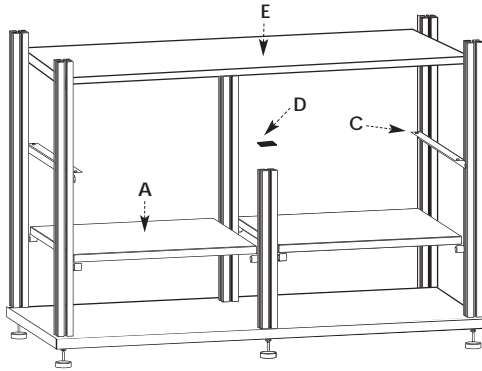

### B. Fine Tuning

Use the bubble level to precisely adjust the adjustable shelves. Be sure to level both sides as well as front to back. Use the hex key to tighten each peg.

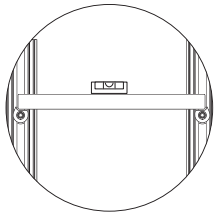

### C. Heavy Duty Bracket

Install heavy duty brackets down outer posts to support the double/triple-width shelf. Place rubber shelf tabs through bracket.

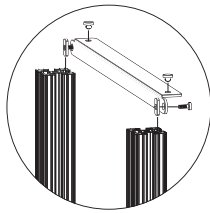

### D. Rubber Pad

Place rubber pads on top of center posts.

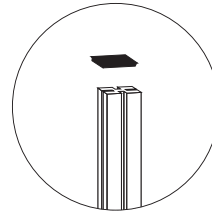

### E. Double-Width Shelf

Place double-width shelf on brackets.

# 5

## Top Assembly

### A. Secure Top

Secure top with the connector bolts.

Place the plastic plugs in the front center holes.

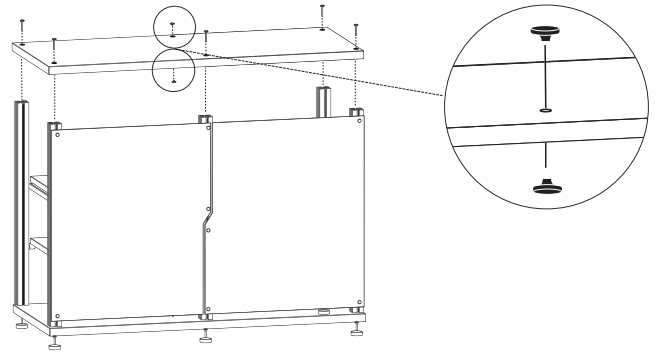

# Parts

- 6 - Aluminum Posts
- 1 - Top Shelf
- 1 - Bottom Shelf
- 1 - Double Width Shelf
- 2 - Adjustable Shelf (SNC30 only)
- 1 - Spacer Tool
- 2 - Rear Panel
- 2 - Heavy Duty Shelf Bracket

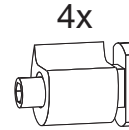
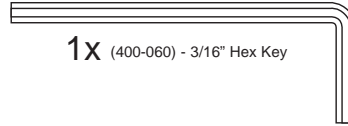

4x  
(PHK-380)  
Shelf Peg "A" - Left  
SNC30 Only

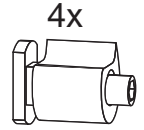

4x  
(PHK-370)  
Shelf Peg "B"- Right  
SNC30 Only

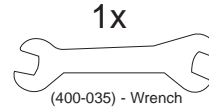

1x

(400-035) - Wrench

6x

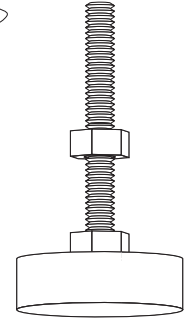

(P-300-320) - Leveler Foot

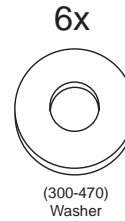

6x

(300-470)  
Washer

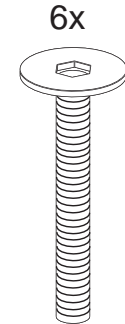

6x

(300-540)  
Connector Bolt

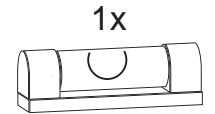

1x

(P-400-040) - Level

## Rear Panel Hardware - (PHK-240)

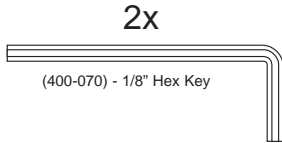

2x

(400-070) - 1/8" Hex Key

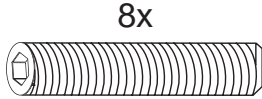

8x

(300-510) - Stud

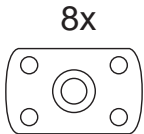

8x

(300-560) - Flat Nut

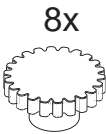

8x

(300-530) - ThumbNut

## Double-Width Shelf Hardware - (PHK-510)



4x

(300-610)  
Rubber Tab

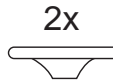

2x

(301-280)  
Cap Plug



1x

(300-265)  
Post Cap



4x

(300-490)  
Low Head Screw

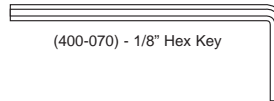

1x

(400-070) - 1/8" Hex Key

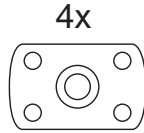

4x

(300-560) - Flat Nut

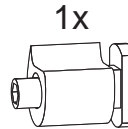

1x

(PHK-380)  
Shelf Peg "A" - Left

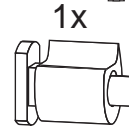

1x

(PHK-370)  
Shelf Peg "B"- Right